



**RM 6**  
**Accessories** **B65808**

**Coil former, squared pins**

Material: GFR thermosetting plastic (UL 94 V-0, insulation class to IEC 60085: H  $\hat{=}$  max. operating temperature 180 °C), color code black  
 Solderability: to IEC 60068-2-20, test Ta, method 1 (aging 3): 235 °C, 2 s  
 Resistance to soldering heat: to IEC 60068-2-20, test Tb, method 1B: 350 °C, 3,5 s  
 Winding: see "Processing Notes", page 153  
 For matching clamp and insulating washers see page 210.

Sections	$A_N$ mm <sup>2</sup>	$l_N$ mm	$A_R$ value $\mu\Omega$	Pins	Ordering code
1	15	30	69	4 5 6 6	B65808-N1004-D1 B65808-N1005-D1 B65808-N1006-D1 B65808-W1006-D1
2	14	30	73	5 6	B65808-N1005-D2 B65808-N1006-D2

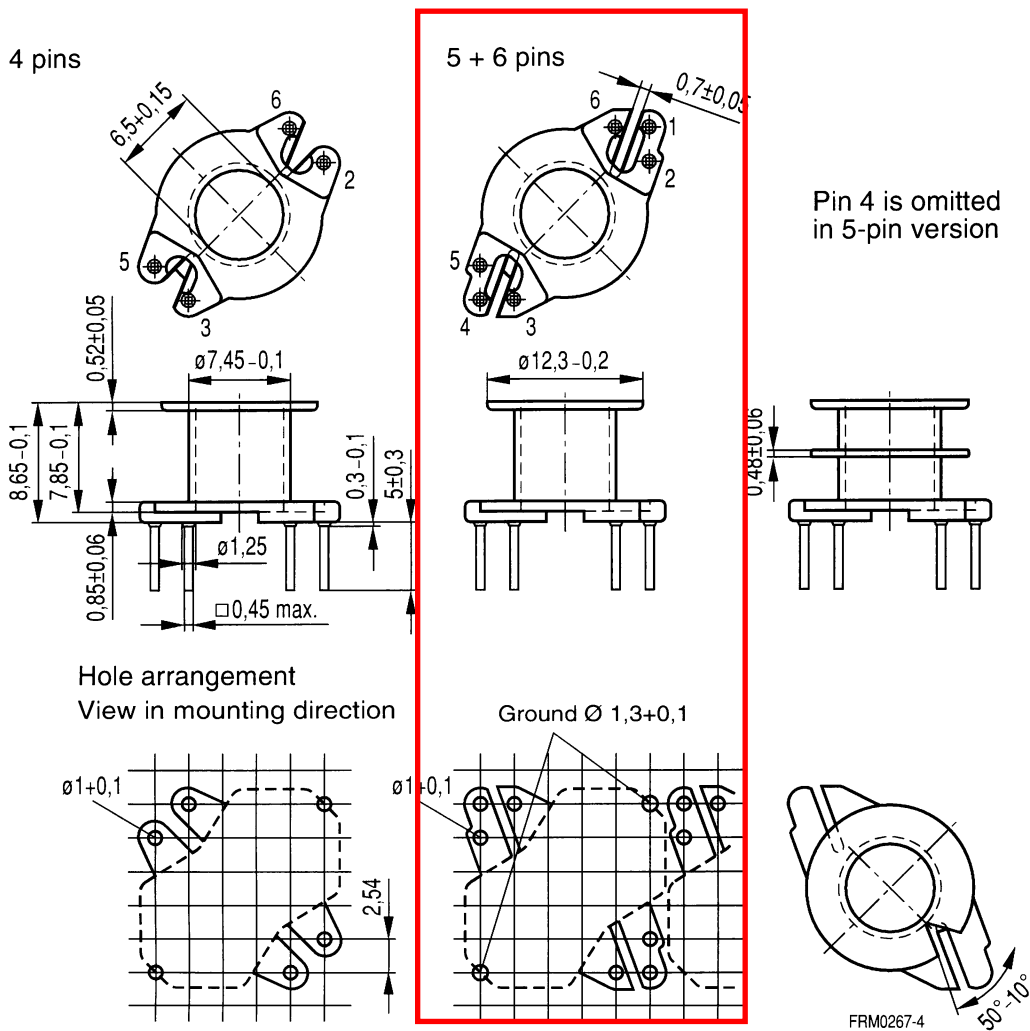

**Coil former, pins squared in the start-of-winding area**

Material: GFR thermosetting plastic (UL 94 V-0, insulation class to IEC 60085:

H  $\geq$  max. operating temperature 180 °C), color code blue

Solderability: to IEC 60068-2-20, test Ta, method 1 (aging 3): 235 °C, 2 s

Resistance to soldering heat: to IEC 60068-2-20, test Tb, method 1B: 350 °C, 3,5 s

Winding: see "Processing Notes", page 153

For matching clamp and insulating washers see page 210.

Sections	$A_N$ mm <sup>2</sup>	$l_N$ mm	$A_R$ value $\mu\Omega$	Pins	Ordering code
1	15	30	69	4	B65808-K1004-D1
				5	B65808-K1005-D1
				6	B65808-K1006-D1
2	14	30	73	4	B65808-K1004-D2
				6	B65808-K1006-D2

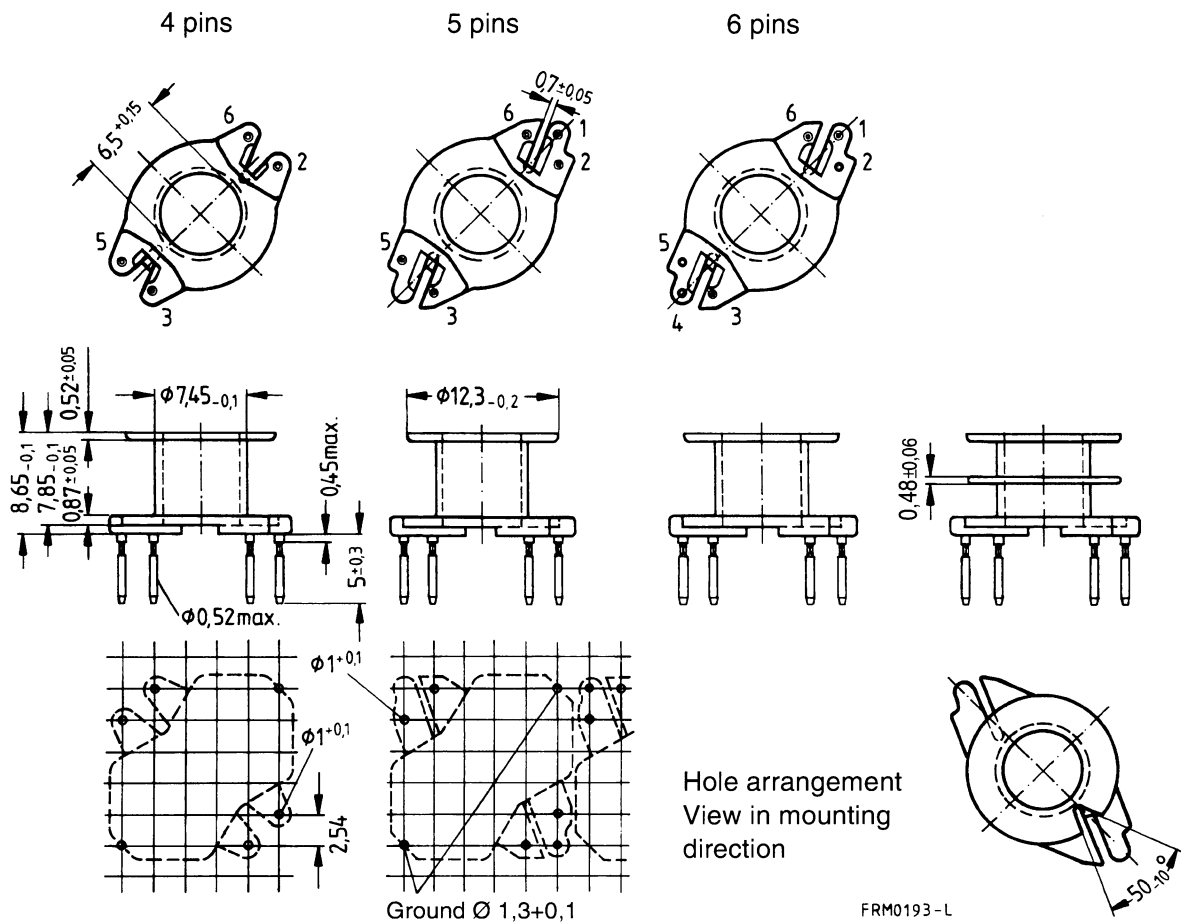

**Coil former for SMPS transformers with line isolation**

The creepage distances and clearances are designed such that the coil former is suitable for use in SMPS transformers with line isolation.

- Closed center flange with external wire guide
- Pins squared in the start-of-winding area
- Optimized for use with automatic winding machines

Material: GFR thermosetting plastic (UL 94 V-0, insulation class to IEC 60085: F  $\geq$  max. operating temperature 155 °C), color code green

Solderability: to IEC 60068-2-20, test Ta, method 1 (aging 3): 235 °C, 2 s

Resistance to soldering heat: to IEC 60068-2-20, test Tb, method 1B: 350 °C, 3,5 s

Winding: see "Processing Notes", page 153

Sections	$A_N$ mm <sup>2</sup>	$l_N$ mm	$A_R$ value $\mu\Omega$	Pins	Ordering code
2	14	30	73	8	B65808-X1108-D2

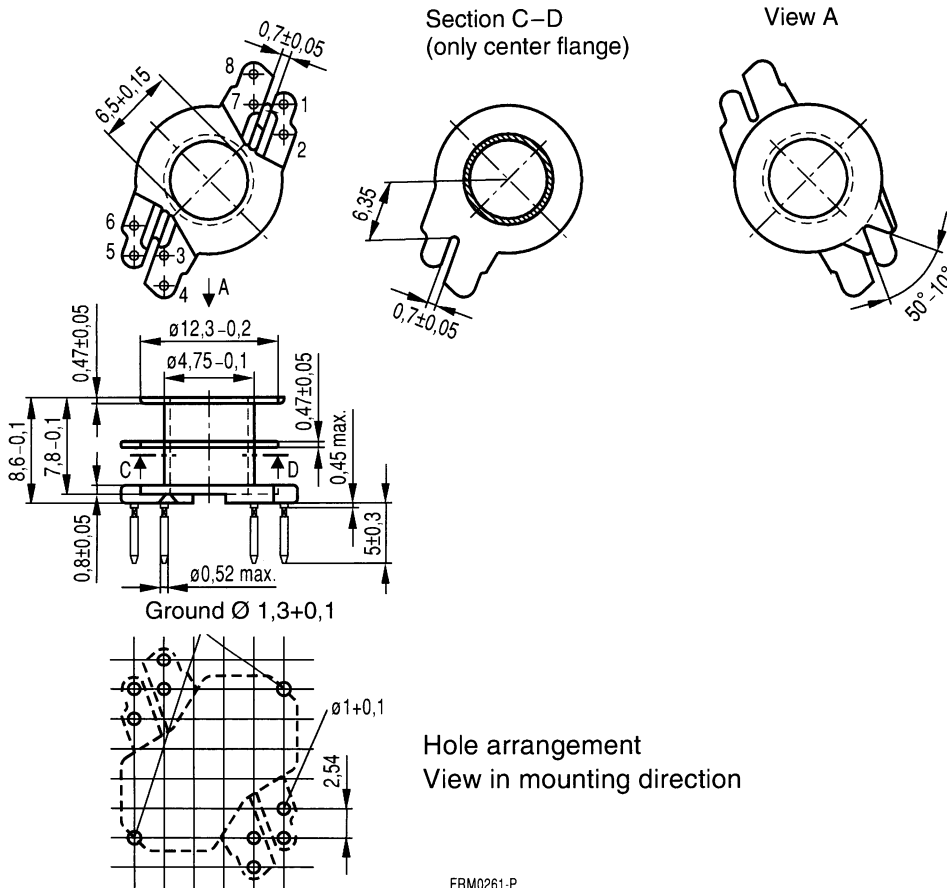

**Coil former for power applications with angled pins**

Optimized for automatic winding

 Material: GFR polyterephthalate (UL 94 V-0, insulation class to IEC 60085:  
 $F \triangleq$  max. operating temperature 155 °C), color code black

Solderability: to IEC 60068-2-20, test Ta, method 1 (aging 3): 235 °C, 2 s

Resistance to soldering heat: to IEC 60068-2-20, test Tb, method 1B: 350 °C, 3,5 s

Winding: see "Processing Notes", page 153

For matching clamp and insulating washer 1 see page 210

Sections	$A_N$ mm <sup>2</sup>	$l_N$ mm	$A_R$ value $\mu\Omega$	Pins	Ordering code
1	15	30	69	8	B65808-E1508-T1

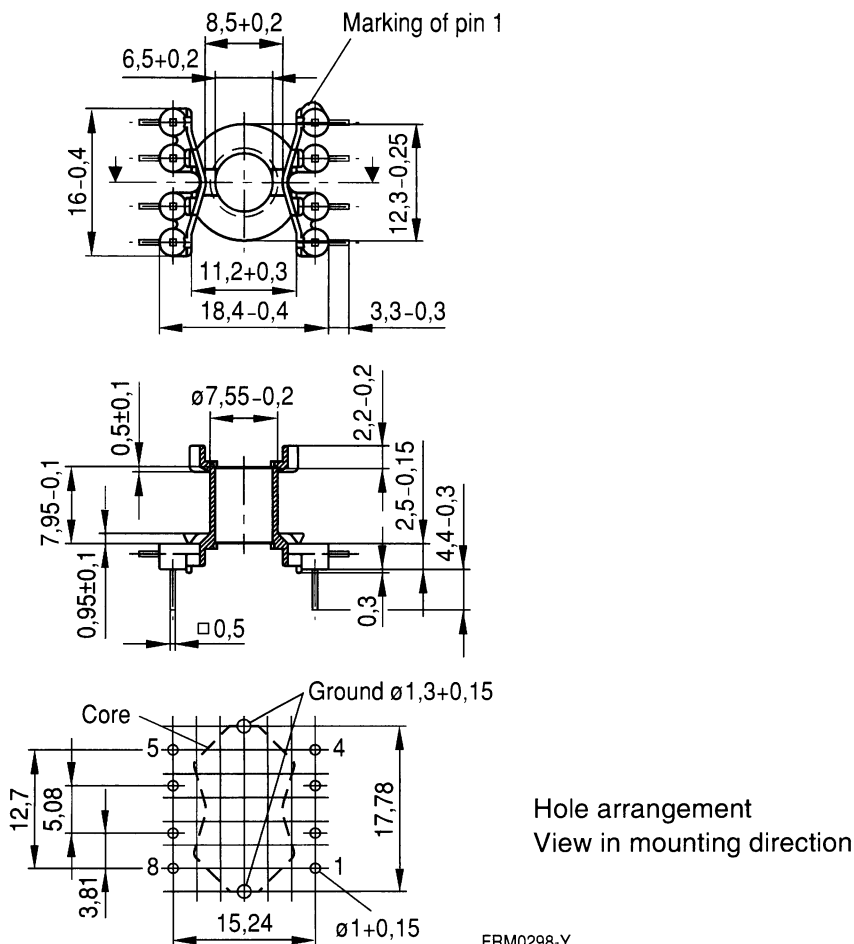

FRM0298-Y

**Coil former for power applications with straight pins**

Optimized for automatic winding

 Material: GFR polyterephthalate (UL 94 V-0, insulation class to IEC 60085:  
 $H \triangleq$  max. operating temperature 180 °C), color code black

Solderability: to IEC 60068-2-20, test Ta, method 1 (aging 3): 235 °C, 2 s

Resistance to soldering heat: to IEC 60068-2-20, test Tb, method 1B: 350 °C, 3,5 s

Winding: see "Processing Notes", page 153

For matching clamp and insulating washer 1 see page 210

Sections	$A_N$ mm <sup>2</sup>	$l_N$ mm	$A_R$ value $\mu\Omega$	Pins	Ordering code
1	15	30	69	8	B65808-W1508-T1

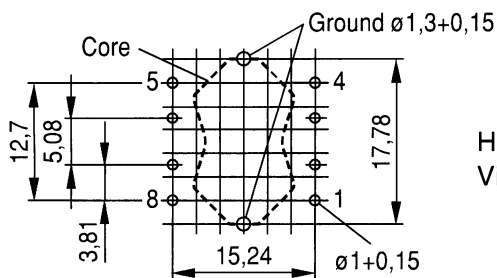
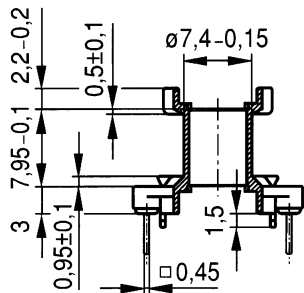
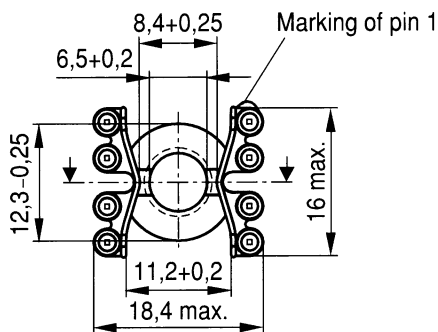
 Hole arrangement  
 View in mounting direction

FRM0299-7

**Clamp**

- With ground terminal, made of stainless spring steel (tinned), 0,435 mm thick
- Solderability to IEC 60068-2-20, test Ta, method 1 (aging 3): 235 °C, 2 s
- Also available as strip clamp on reels

**Insulating washer 1** between core and coil former

- For tolerance compensation and for insulation
- Made of polycarbonate (UL 94 V-0, insulation class to IEC 60085: E  $\geq$  120 °C), 0,08 mm thick

**Insulating washer 2** for double-clad PCBs

- Made of polycarbonate (UL 94 V-0, insulation class to IEC 60085: E  $\geq$  120 °C), 0,3 mm thick

	Ordering code
Clamp (ordering code per piece, 2 are required)	B65808-A2203
Insulating washer 1 (reel packing, PU = 1 reel)	B65808-A5000
Insulating washer 2 (bulk)	B65808-C2005

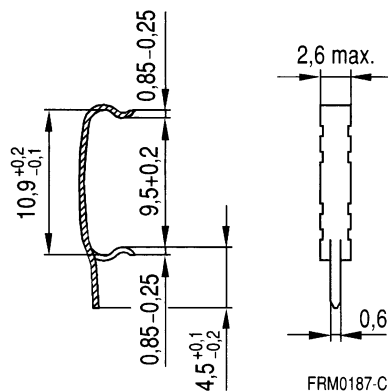
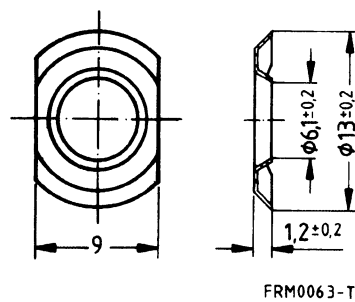
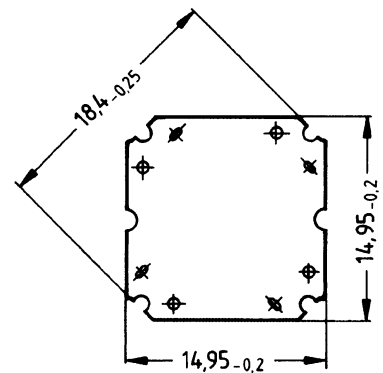
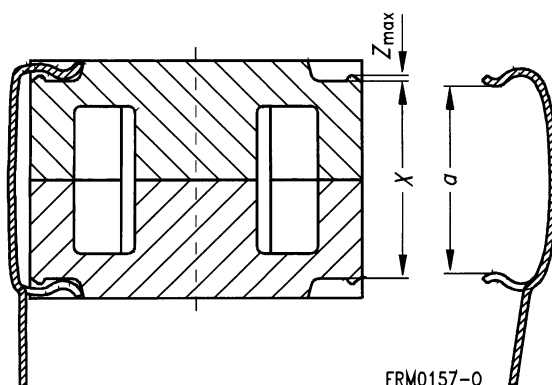
**Clamp**

**Insulating washer 1**

**Insulating washer 2**

**Clamping forces for RM 6**

$F_{min}$ : Extension of clamp from  $a$  to  $a_2 = X_{min}$   
 $F_{max}$ : Extension of clamp from  $a$  to  $a_1 = X_{max}$

Clamp opening $a$ (mm)		9,5 + 0,2
Core nose $Z_{max}$ (mm)		0,22
Height of core pair $X$ (mm)	$X_{min}$	10,1
	$X_{max}$	10,6
Clamping force $F$ (N)	$F_{min}$	7
	$F_{max}$	50

**SMD coil former with gullwing terminals**

Material: GFR liquid crystal polymer (UL 94 V-0, insulation class to IEC 60085:  
F  $\triangleq$  max. operating temperature 155 °C), color code black

Solderability: to IEC 60068-2-20, test Ta, method 1 (aging 3): 350 °C, 1 s

Resistance to soldering heat: to IEC 60068-2-20, test Tb, method 1B: 350 °C, 3,5 s

permissible soldering temperature for wire-wrap connection on coil former: 400 °C, 1 s

Winding: see "Processing Notes", page 160

**Clamp**

- Without ground terminal, made of stainless spring steel, 0,435 mm thick
- Also available as strip clamp (each carton containing 2 reels) on request

Sections	$A_N$ mm <sup>2</sup>	$l_N$ mm	$A_R$ value $\mu\Omega$	Terminals	Ordering code
1	16,2	31	66	8	B65821-C1008-T1
2	15,2	31	69	8	B65821-C1008-T2
Clamp	(ordering code per piece, 2 are required)				B65808-J2204

**Coil former**

1 section

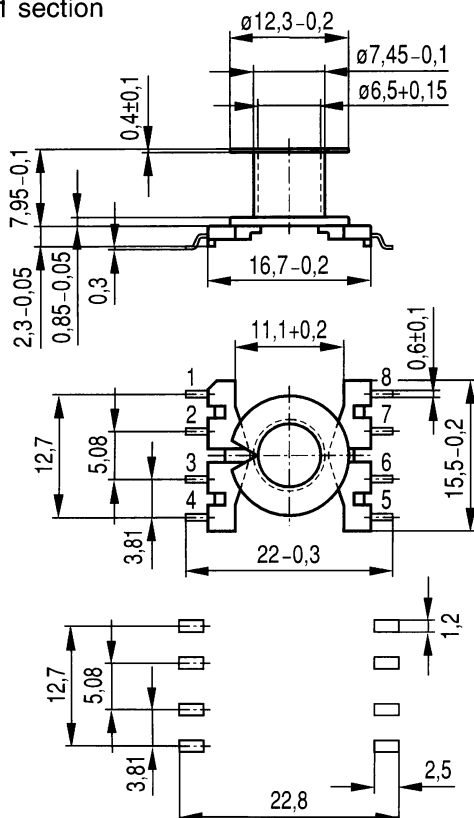
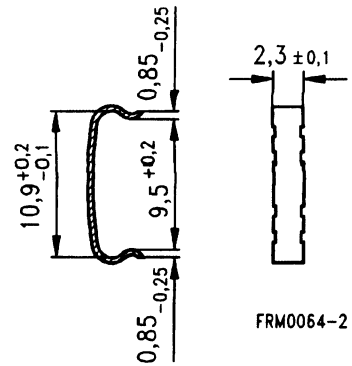
**Clamp**

 Recommended  
PCB layout

FRM0238-Q

**SMD coil former with J terminals**

Material: GFR liquid crystal polymer (UL 94 V-0, insulation class to IEC 60085:

F  $\triangleq$  max. operating temperature 155 °C), color code black

Solderability: to IEC 60068-2-20, test Ta, method 1 (aging 3): 350 °C, 1 s

Resistance to soldering heat: to IEC 60068-2-20, test Tb, method 1B: 350 °C, 3,5 s

permissible soldering temperature for wire-wrap connection on coil former: 400 °C, 1 s

Winding: see "Processing Notes", page 160

**Clamp**

- Without ground terminal, made of stainless spring steel, 0,435 mm thick
- Also available as strip clamp (each carton containing 2 reels) on request

Sections	$A_N$ mm <sup>2</sup>	$l_N$ mm	$A_R$ value $\mu\Omega$	Terminals	Ordering code
1	16,2	31	66	8	B65821-J1008-T1
Clamp	(ordering code per piece, 2 are required)				B65808-J2204

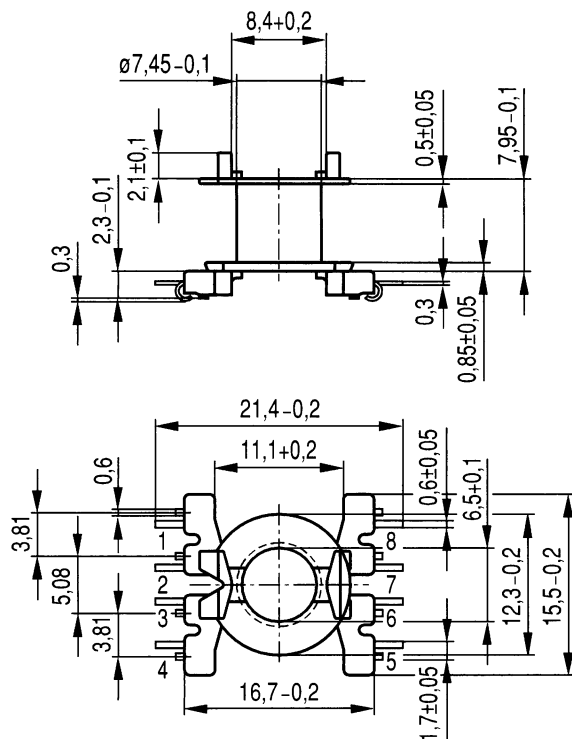
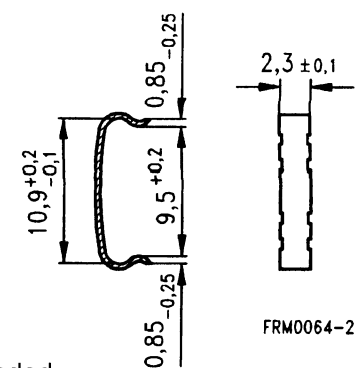
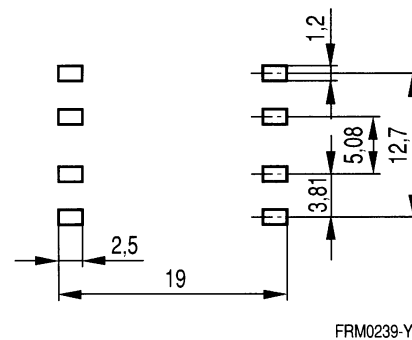
**Coil former**

**Clamp**

**Recommended PCB layout**



**Adjusting screw**

■ Tube core with thread and core brake made of GFR polyterephthalate

Plastic **adjusting screwdriver** (not shown)

Plastic **handle** for adjusting screwdriver (not shown)

Core RM 6		Adjusting screw				Min. adjusting range %	Ordering code
Material	A <sub>L</sub> value nH	Fig.	Tube core ∅ × length mm	Material	Color code		
K 1	40	a	2,62 × 3,7	Si 1	white	15	B65659-F1-X101
M 33	63	a	2,62 × 3,7	Si 1	white	17	B65659-F1-X101
	100	c	2,82 × 4,4	Si 1	brown	16	B65659-F4-X101
N 48	160	a	2,62 × 3,7	K 1	green	17	B65659-F1-X1
	250	a	2,62 × 3,7	N 22	red	11	B65659-F1-X23
	315	b	2,75 × 4,4	N 22	black	13	B65659-F3-X23
	400	c	2,82 × 4,4	N 22	yellow	11	B65659-F4-X23
<b>Adjusting screwdriver</b>							B63399-B4
<b>Handle</b>							B63399-B5

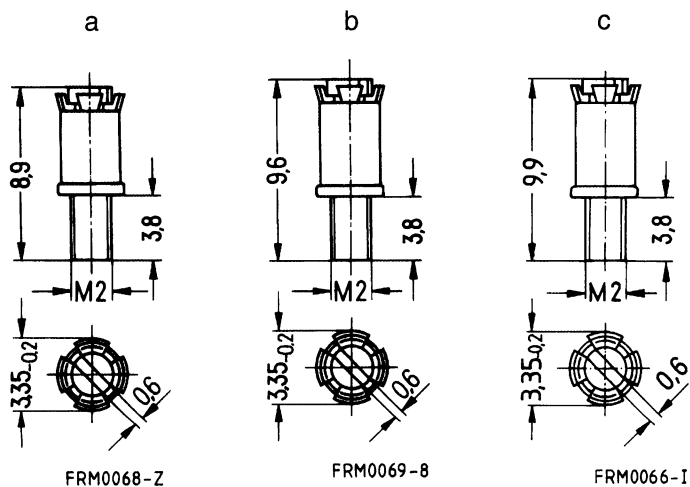
**Adjusting screws**

**Herausgegeben von EPCOS AG**

**Marketing Kommunikation, Postfach 80 17 09, 81617 München, DEUTSCHLAND**

© EPCOS AG 2000. Alle Rechte vorbehalten. Vervielfältigung, Veröffentlichung, Verbreitung und Verwertung dieser Broschüre und ihres Inhalts ohne ausdrückliche Genehmigung der EPCOS AG nicht gestattet.

Mit den Angaben in dieser Broschüre werden die Bauelemente spezifiziert, keine Eigenschaften zugesichert. Bestellungen unterliegen den vom ZVEI empfohlenen Allgemeinen Lieferbedingungen für Erzeugnisse und Leistungen der Elektroindustrie, soweit nichts anderes vereinbart wird.

Diese Broschüre ersetzt die vorige Ausgabe.

Fragen über Technik, Preise und Liefermöglichkeiten richten Sie bitte an den Ihnen nächstgelegenen Vertrieb der EPCOS AG oder an unsere Vertriebsgesellschaften im Ausland.

Bauelemente können aufgrund technischer Erfordernisse Gefahrstoffe enthalten. Auskünfte darüber bitten wir unter Angabe des betreffenden Typs ebenfalls über die zuständige Vertriebsgesellschaft einzuholen.

**Published by EPCOS AG**

**Marketing Communications, P.O. Box 80 17 09, 81617 Munich, GERMANY**

© EPCOS AG 2000. All Rights Reserved. Reproduction, publication and dissemination of this brochure and the information contained therein without EPCOS' prior express consent is prohibited.

The information contained in this brochure describes the type of component and shall not be considered as guaranteed characteristics. Purchase orders are subject to the General Conditions for the Supply of Products and Services of the Electrical and Electronics Industry recommended by the ZVEI (German Electrical and Electronic Manufacturers' Association), unless otherwise agreed.

This brochure replaces the previous edition.

For questions on technology, prices and delivery please contact the Sales Offices of EPCOS AG or the international Representatives.

Due to technical requirements components may contain dangerous substances. For information on the type in question please also contact one of our Sales Offices.